

CARBON MONOXIDE TRANSDUCER AND METER

Parking Garage Warehouse Maintenance Facility
Ice Skating Arena Storage Facility



CM-2B

- Analog Transducer, 4 to 20 ma
- Low maintenance, no periodic calibration required
- Long sensor life (7 – 10 years)
- Works with any Building Automation System or other control device
- Digital display, 0 – 250 PPM of Carbon Monoxide

FEATURES:

- General guideline on spacing: 5000 sq ft per unit.
- Locate detector 4 to 5 feet above the floor.
- The **CM-2B** connects to any Building Automation System accepting a 4 to 20 ma.
- The **CM-2B** has 1000 volt isolated output, common power buses can be used. Microprocessor controlled digital display and analog output.
- The **CM-2B** is housed in a UL knockout box, facilitating installation and hook-up.
- Low voltage operation. Power input 24 VDC or 24 VAC.
- Field Calibration Kits (**CM-2B-FCK**) are available.
- Works into a wide range of loads, namely 0 to 1000 ohms.
- Supervised solid-state sensor – low maintenance.

Ma to CO Graph

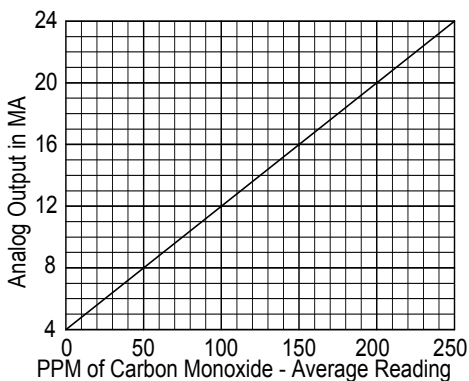

SPECIFICATIONS:

- Power: 3.5 watts (22 to 26.5 VAC or VDC)
- Output: 4 to 20 milliamps (ma)
- Range: 0 – 250 PPM of Carbon Monoxide
- Operating Envir: 0 to 125F, 10 to 90% RH
- Repeatability: $\pm 10\%$ at 50 PPM of CO
- Linearity: $\pm 10\%$
- Size: 6 X 6 X 3 inches
- Shipping Weight: 3 lbs
- Color: Gray

AUTHORIZED DISTRIBUTOR:

GasDetectorsUSA.com
Houston, Texas USA
sales@GasDetectorsUSA.com
832-615-3588

CM-2B APPLICATIONS

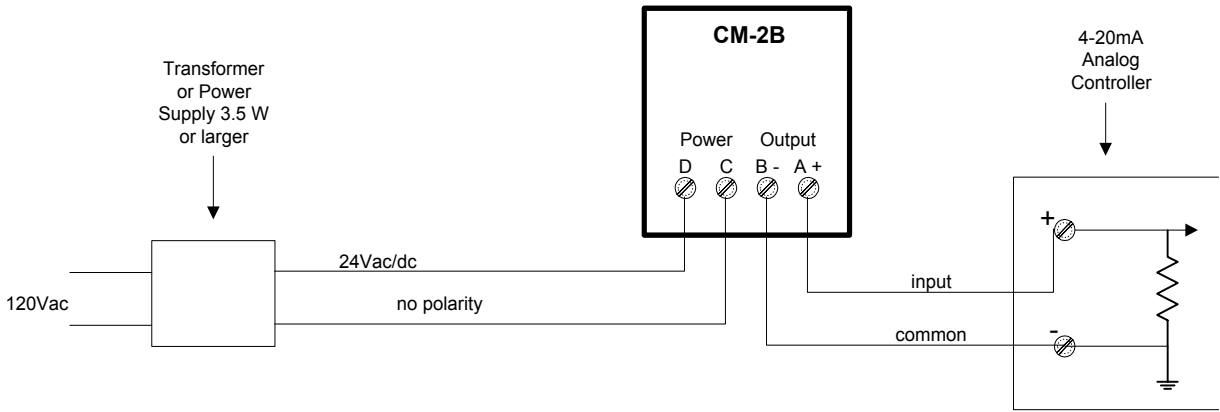

MULTIPLE CM-2B SYSTEM

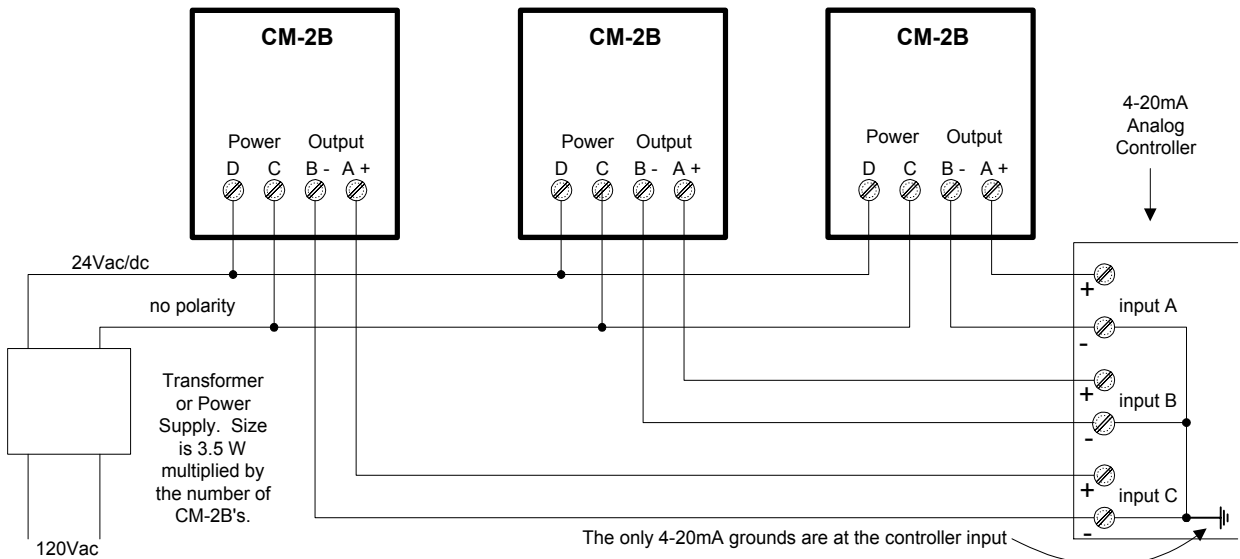

TYPICAL LAYOUT IN A PARKING GARAGE

Notes:

1. One detector per 5000 square feet.
2. CM-2B should mount on walls or columns 5 feet above floor.
3. Size fans per building code.
4. There must be adequate air-flow through building/garage/structure.

